

# ASTRO-PHYSICS

## Replacing the Latitude Adjuster of 1200 German Equatorial

### 12ALKIT part list

S1200AA-A Altitude Adjuster Brace Assembly with Altitude Knob, Threaded Rod and Tommy Bar  
four ¼-20 x ¾" socket cap screws

### 12ALBKIT part list

M12150-A Altitude Adjuster Brace  
Four ¼-20 x ¾" socket cap screws

### Mounts that can be upgraded:

All 1200 mounts that have been produced, i.e. models designated as HDA (Quartz Controller), QMD (Quartz Micro-Drive Controller), SMD (Servo – non-go-to) and GTO (go-to).

### Replacing the Latitude Adjuster

Do not attempt this with the telescope or declination axis attached. You should be working with the RA axis only. Before attempting to remove the altitude adjuster bar, you must raise the RA axis to its maximum altitude position, and then tighten the altitude-locking knob on the motor/gear housing side. This will prevent any downward movement of the polar axis during positioning of the altitude adjuster bar. ( See #'s 3 & 4 below.) Remove the current altitude adjuster bar from your mount.

12ALBKIT – Since you have just purchased the brace (not the assembly), you will have to install the original components onto the new brace. Do not attempt to disassemble the brass component. Instead, loosen the setscrew on the large black knob and thread the knob from the rod. Then, remove the threaded rod.

12ALKIT – Your assembly is complete. You do not need any parts from the original assembly.

The directions below come from the 1200 manual and can be used as a guide for initial installation or changing the position in the future. Please read the instructions through and apply to your situation.

The latitude range of the 1200 mount is approximately 21.5 - 68 degrees. Since most astronomers typically observe within one latitude range, this adjustment is made just once, if at all. We suggest that before you travel to an observing location, determine the approximate latitude of your observing site and make the appropriate rough adjustment. If you live in or plan to travel to locations that are 0-20 degrees latitude, we recommend our wedge (1200WDG).

The four positions for the altitude adjustments have the following approximate ranges:

- 55 degrees to 68 degrees latitude - top position
- 37 degrees to 59 degrees latitude - second position
- 28 degrees to 50 degrees latitude - third position
- 21.5 degrees to 34 degrees latitude - bottom position

### How to change the position of the altitude adjuster

1. Use only the R.A. axis. DO NOT attempt to make these adjustments with the declination axis in place and certainly not with an instrument fully mounted.
2. Loosen both altitude-locking knobs about 1 turn.
3. Locate the side of the polar axis that does not have the motor/gear housing box. Loosen (about 1 turn) the polar axis pivot screw and altitude adjuster bar fixing screws on this side only. With your hand, push the polar axis upwards so that the altitude-locking knobs are positioned at the top of the altitude slot (this is the maximum altitude position). Some resistance will be felt with this operation as you are pushing against the

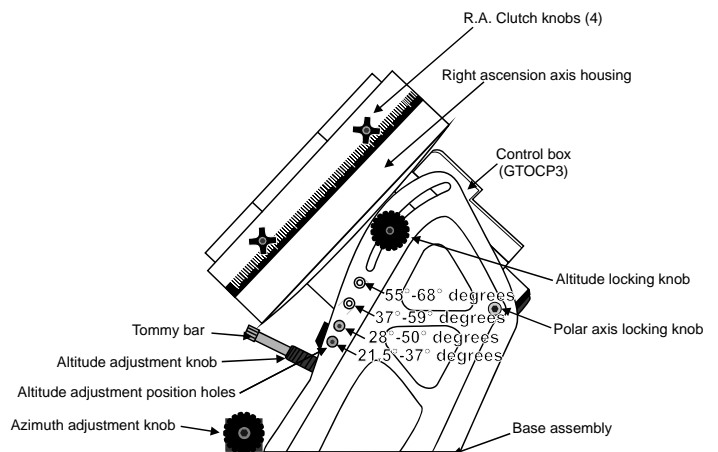
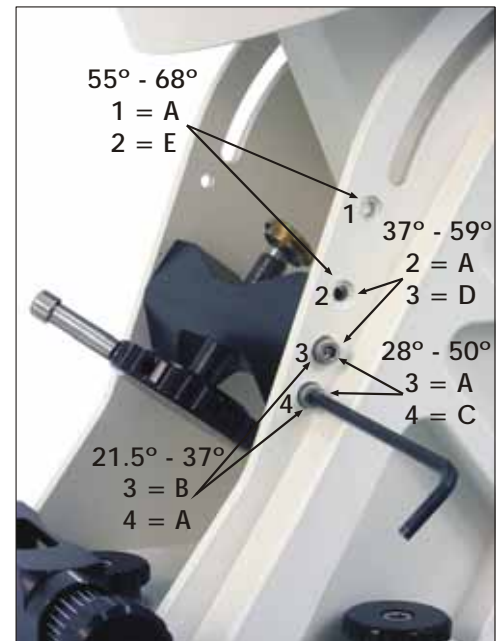
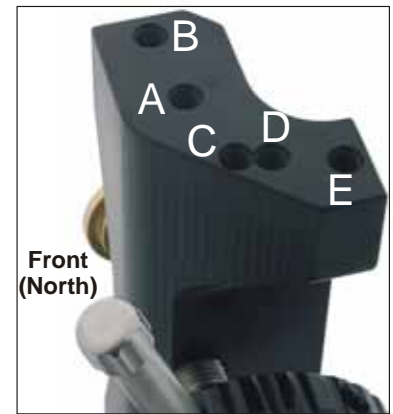
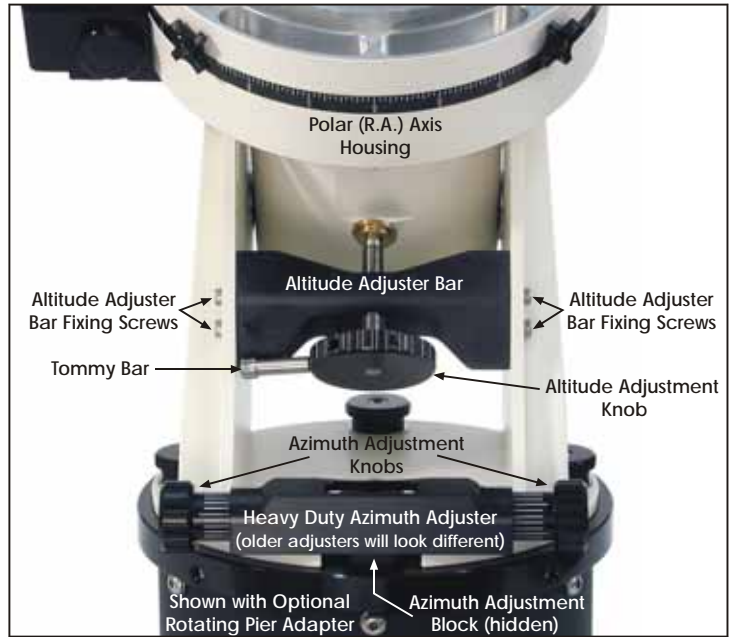

Diagram 3

weight of the polar housing and the resistance of the remaining polar axis pivot screw (which has not been loosened).

4. Before attempting to remove or move the altitude adjuster bar, you must tighten the altitude-locking knob on the motor/gear housing side. This will prevent any downward movement of the polar axis during positioning of the altitude adjuster bar.
5. While supporting the altitude adjuster bar, remove the two screws that support it on each side (4 screws in all). If upgrading, gently remove your old Altitude Adjuster Bar. If you are changing latitude positions, keep the two ends of the bar in contact with the side of the mount, don't remove it completely (this tip is for your convenience).
6. Determine the latitude range that you need and position the altitude adjuster bar so that the hole that is marked "A", as shown in the diagram, is located at the appropriate hole position numbered 1-4 in the lower diagram. Note that hole "A" is located at the rounded part in the center of the altitude bar. Hole "A" is the "latitude hole."
7. Attach two of the screws (one on either side of the adjuster bar) through the appropriate altitude adjustment position hole and into hole A of the adjuster bar, but do not tighten. Rotate the altitude adjuster bar around this pivot point until the corresponding hole lines up. Consult the diagram to determine which hole of the altitude adjuster bar should be used. Be very careful since the holes marked C and D are very close to one another. The incorrect hole may appear to line up, however it will be slightly off. If you try to attach at the incorrect hole, you may strip the threads of the altitude bar. The correct hole will orient the adjuster to be roughly perpendicular to the axis once the axis is lowered into place.
8. Once you have located the correct hole, insert the remaining two screws, and lightly tighten so that you still have some ability to wiggle the bar.
9. Note that the altitude adjustment knob is attached to a threaded rod that travels through the altitude adjuster bar. Turn the knob so that the altitude adjuster bar is positioned approximately in the middle of the threaded rod. You should see about half of the threaded rod protruding from both sides of the altitude adjuster bar. This will allow you to move the mount fully within the altitude range.
10. At the end of the threaded rod mentioned in the last step, you will see a small brass altitude adjuster thrust pad. This is the part that will come in contact with the polar axis as you ease it back into position. Loosen the altitude-locking knob (motor/gear side) and lower the polar axis so that it rests comfortably on this pad. The threaded rod should be positioned at roughly a right angle to the polar axis housing. Firmly tighten the altitude adjuster bar fixing screws.
11. Turn the altitude adjustment knob to raise or lower the polar axis to your approximate observing latitude. Tighten the altitude locking knobs with finger pressure only. You do not need to tighten with the hex key.
12. Firmly tighten both polar axis pivot screws with the hex key.



2-1-06