

ASTRO-PHYSICS

600E GERMAN EQUATORIAL MOUNT WITH DUAL AXIS QUARTZ DRIVE (600EDA)

MODEL 600E PARTS LIST

- 1 600E Equatorial Head with dual axis drive
- 1 Cradle Plate and four screws (FP600E is standard unless you purchased a dovetail plate)
- 1 Stainless counterweight shaft with washer stop and black plastic knob (5/16-18 threaded rod)
- 1 Dual axis quartz frequency control box with cord
- 1 D.C. power cord (cigarette lighter adapter)
- 3 Black plastic knobs with 1/4-20 threaded rod
- 1 5 and 10mm hex keys
- 2 Red caplugs
- 1 Piece of Velcro (to attach hand controller to surface of your choice)

In order to fully assemble and use your mount, you will need the following items, separately sold: pier or tripod, portable rechargeable battery pack and counterweights. Several sizes and types are available for your selection. Many of these items will be discussed throughout these instructions.

Several additional options will help to enhance your observing experience: dovetail mounting plate, polar axis telescope with illuminator; high resolution mounted encoders and JMI computerized digital setting circles, Santa Barbara Instrument Group ST-4 or ST-6 CCD imaging camera/autoguider.

INTRODUCTION

If you were to take a long exposure photograph with Polaris (often called the North Star) in the center of the field, you would discover that all stars seem to revolve around Polaris. This effect is due to the rotation of the earth on its axis. Motor driven equatorial mounts were designed to compensate for the earth's rotation by moving the telescope at the same rate and opposite to the earth's rotation. When the polar axis of the telescope is pointed at the celestial pole (polar aligned) as shown in the diagram on the right, the mount will follow (track) the motions of the sun, moon, planets, and stars. As a result, the object that you are observing will appear motionless as you observe through the eyepiece or take astrophotos.

For visual observation, a rough sighting of Polaris through the hole in the polar axis is fine. However if astrophotography is your goal, accurate polar alignment is critical.

We recommend that you familiarize yourself with the assemble and basic operation of the mount indoors. The temperature will be comfortable, the mosquitoes at bay, and you'll have enough light to see the illustrations and read the manual. Please take particular note of counterbalancing, use of the clutches and operation of the hand controller.

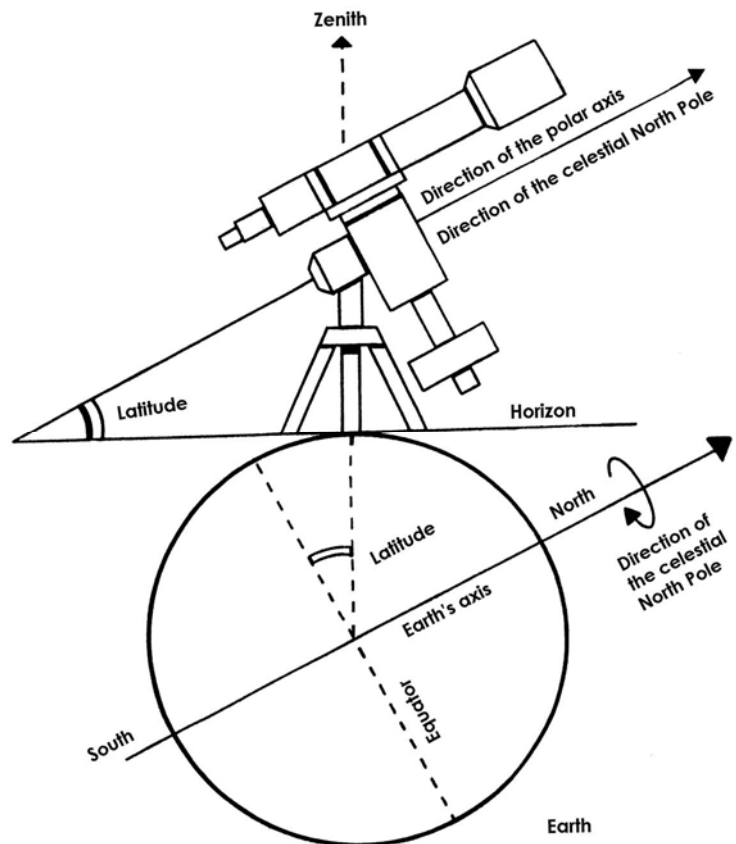

ASSEMBLY INSTRUCTIONS

Please read all instructions before attempting to set up your 600E mount. The Model 600E is very rugged, however like any precision instrument, it can be damaged by improper use and handling. Please refer to the diagram below for illustrations of the mount. The parts are labeled so that we can establish common terminology.

The following terms and abbreviations may be used interchangeably in these instructions:

Polar axis = right ascension axis = R.A. axis = R.A. housing

Declination axis = Dec. axis = Dec. housing

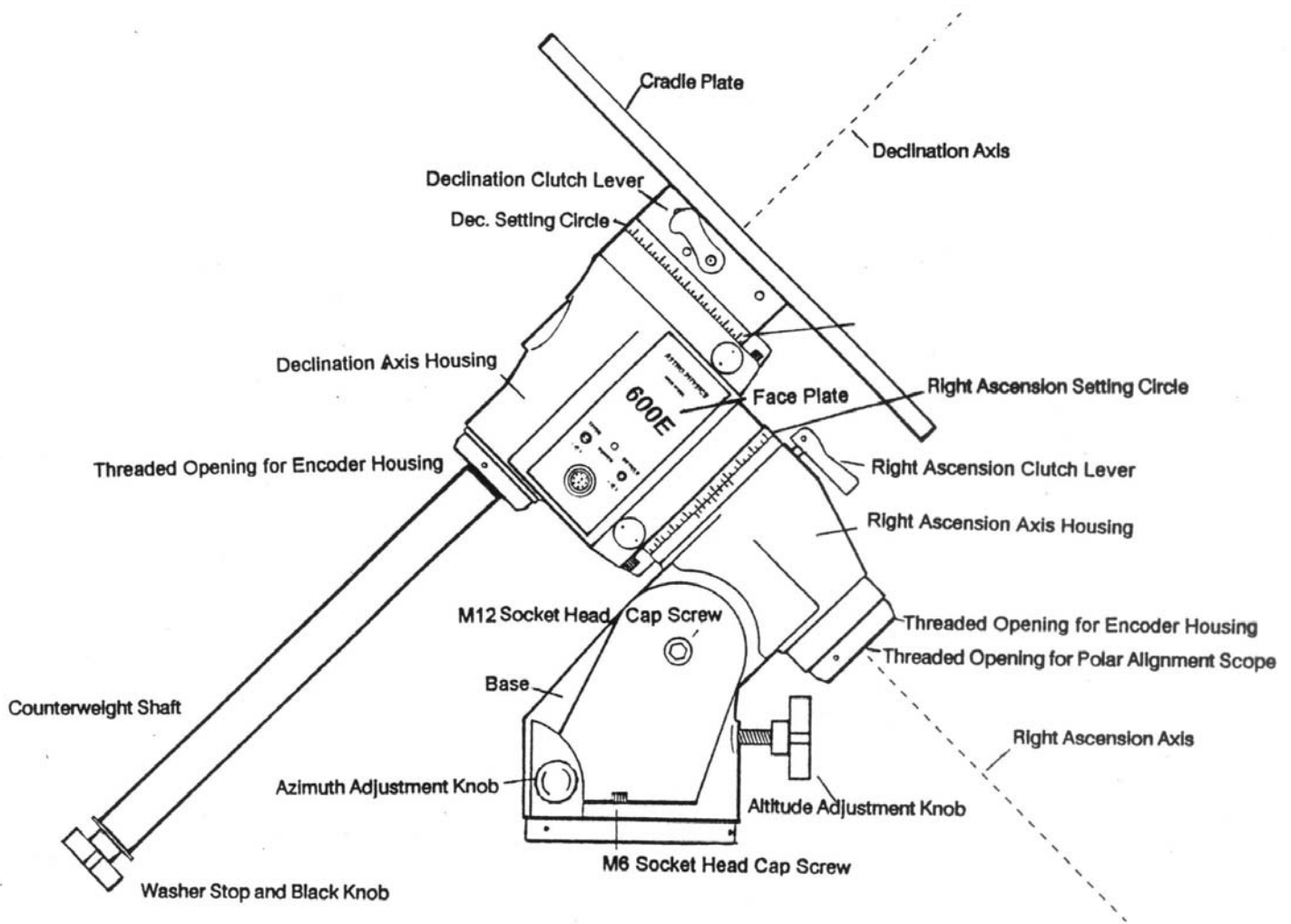

ASSEMBLE PIER OR TRIPOD

Begin by assembling the pier or tripod at the desired observing location.

ADJUSTABLE HARDWOOD TRIPOD: Remove the tripod from its carrying case and attach the shelf to each of the three legs with the knobs provided. Adjust legs to the desired height and spread. Lock in position with the hand knobs. Please refer to the diagram below.

PORTABLE PIER: Slide the three legs onto the nubs of the base. Place the pier post on the base and attach the tension rods. The turnbuckles should be drawn tight until the whole assembly is stiff enough to support your weight without movement. Please refer to the diagram below.

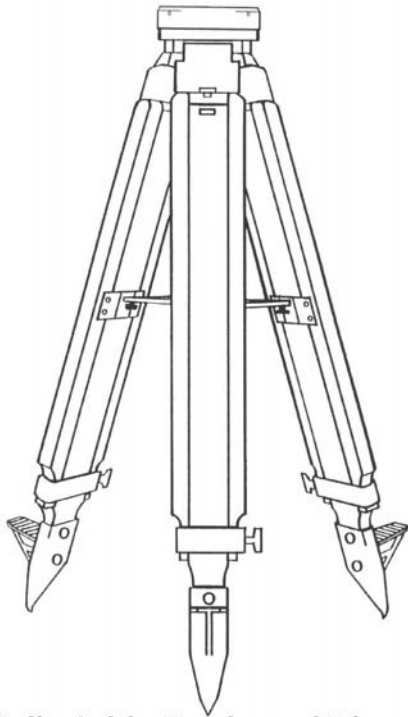

Adjustable Hardwood Tripod

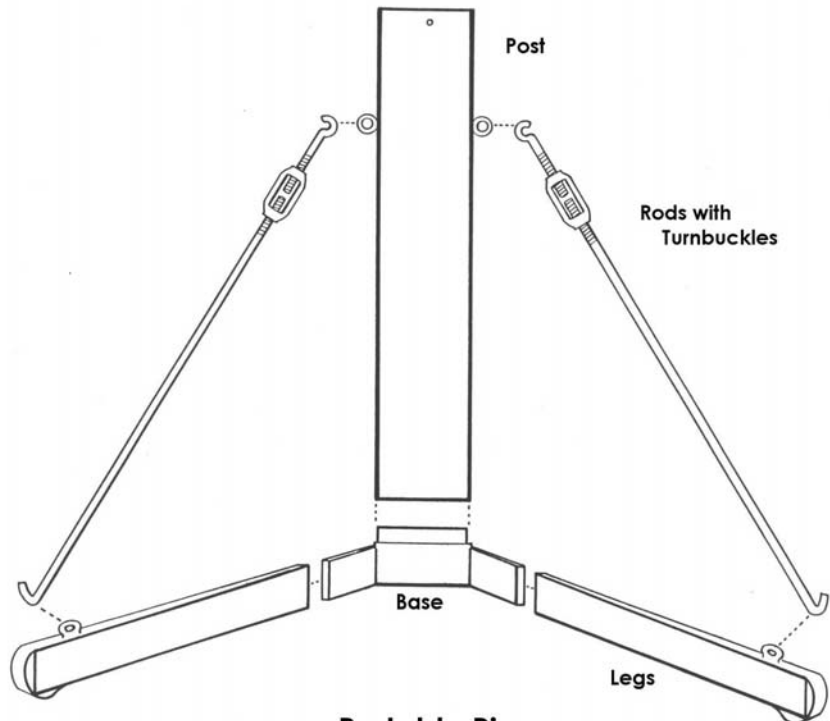

Portable Pier

ASSEMBLE MOUNT TO PIER OR TRIPOD

In order to track the motion of astronomical objects, the polar axis must be positioned so that an imaginary line drawn through the hollow shaft points toward the celestial pole. At this stage of the assembly process, you want to position the mount so that it points roughly north. Place the mount into the top of the pier or tripod so that the threaded R.A. axis hole is on the south side of the pier/tripod. Line up the holes of the mount and pier/tripod. Screw in the three hand knobs to hold the mount in place.

ALTITUDE AND AZIMUTH ADJUSTMENTS – ROUGH POLAR ALIGNMENT

Follow these instructions if you want to rough polar align your mount. If not, you may skip this section and move onto *Assemble Cradle Plate and Counterweight Shaft*. You may make these adjustments with the telescope mounted or not, according to your preference. If you plan to mount your scope at this stage, refer to the *Assemble Cradle Plate and Counterweight Shaft* section first.

1. If you examine the polar axis assembly, you will see that center of the polar shaft is hollow. You may need to rotate the internal declination shaft by moving the top of the declination axis (or the cradle plate if it is attached) to align the sight hole that has been drilled into it. Now, you can look through the shaft to the other side. The end of the R.A. axis is threaded to accept the optional polar alignment telescope. You do not need the polar alignment scope for this part of the process.
2. Use the 5mm hex key to loosen the M6 socket head cap screw on each side of the mount base. Loosen the two M12 socket head screws on each side of the mount using the 10mm hex key provided.

3. Your goal is to sight Polaris when looking through the polar alignment sight hole in the center of the polar axis. You will need to make altitude and azimuth adjustments to the position of the mount.
4. Altitude (latitude) adjustments: Move the polar axis up or down with the large altitude adjustment knob located at the rear of the mount assembly.

5. Azimuth adjustments: Move the entire pier or tripod east or west until the mount is oriented approximately towards the pole. Use the two fine azimuth adjustment knobs, one on each side of the mount, to make fine adjustments in azimuth. You must back off the opposing azimuth knob in order to move the other knob in that direction. Please refer to the diagram to the right.

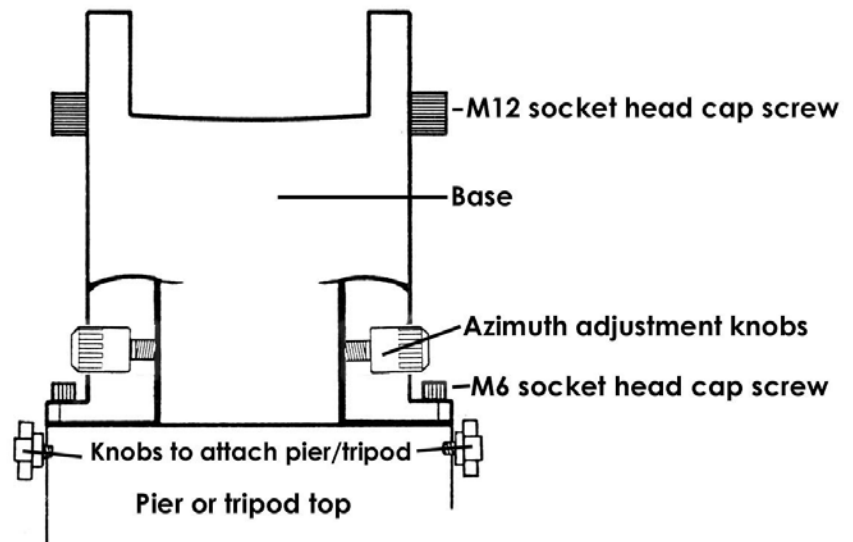

6. You will continue to make adjustments in azimuth and altitude until you can see Polaris through the polar alignment sight hole. At this point, you have achieved rough polar alignment, which may be sufficient for most casual visual observations. When the R.A. motor is engaged, it will compensate for the rotation of the earth and keep the target object within the eyepiece field of view. Your target object will slowly drift since polar alignment at this stage is only approximate. However, you can make corrections with your hand controller, as we will discuss later.
7. If rough polar alignment is sufficient, snug the two M6 socket head cap screws and two M12 socket head cap bolt to lock the mount into position. If you require more exact polar alignment, do not tighten yet and proceed to the next section.

FINE POLAR ALIGNMENT – not necessary for casual observation

Follow these instructions if you want to fine-tune the polar alignment of your mount. If not, you may skip this section and move onto “Assemble Cradle Plate.”

1. Polar alignment telescope – The north celestial pole can be viewed through the polar axis with our optional polar alignment telescope. Please read the instructions sheets for the polar alignment telescope.
2. If you do not have a polar alignment telescope, you may use the star drift method. Please refer to the recommended reading list at the end of this manual.
3. When the proper alignment has been achieved, snug the two M12 screws and two M6 socket head cap screws lightly to secure the polar axis and recheck alignment. If no movement has occurred, finish tightening the screw as much as possible to prevent movement when the telescope and counterweights are attached.

IMPORTANT: Failure to tighten the side screw can cause the axis to slip, with resultant damage to the mount.

ASSEMBLE CRADLE PLATE

Attach the cradle plate to the top of the declination axis with the four M6 screws provided with the mount. If you have purchased a Dovetail Mounting Plate and Sliding bar you may wish to refer to the instruction sheet entitled *Cradle Plate Options* for more information. When you have finished your observing session, the cradle plate may remain attached to the declination axis or removed as desired.

ASSEMBLE COUNTERWEIGHT SHAFT

IMPORTANT: Always attach the counterweights before mounting the telescope to prevent sudden movement of an unbalanced tube assembly, which may cause damage or injury. Remember that the counterweights are heavy and will hurt if they fall on your foot.

1. Thread counterweight shaft onto the Dec. axis.
2. Remove the hand knob and washer from the base of the counterweight shaft. Add sufficient counterweights (6 or 9 lb. counterweights are available) to the counterweight shaft to balance the telescope you intend to use. Always use two hands to attach or move them on the shaft. Reattach the hand knob and washer to the end of counterweight shaft. This will help to prevent injury if someone accidentally loosens the counterweight hand knob.

A firm tightening of the counterweight knob will not damage the surface of the counterweight shaft. The pin that tightens against the stainless counterweight shaft is constructed of brass. Likewise, the bronze sleeve that has been press fit into the center of the counterweight will prevent marring of the shaft as you move the counterweights.

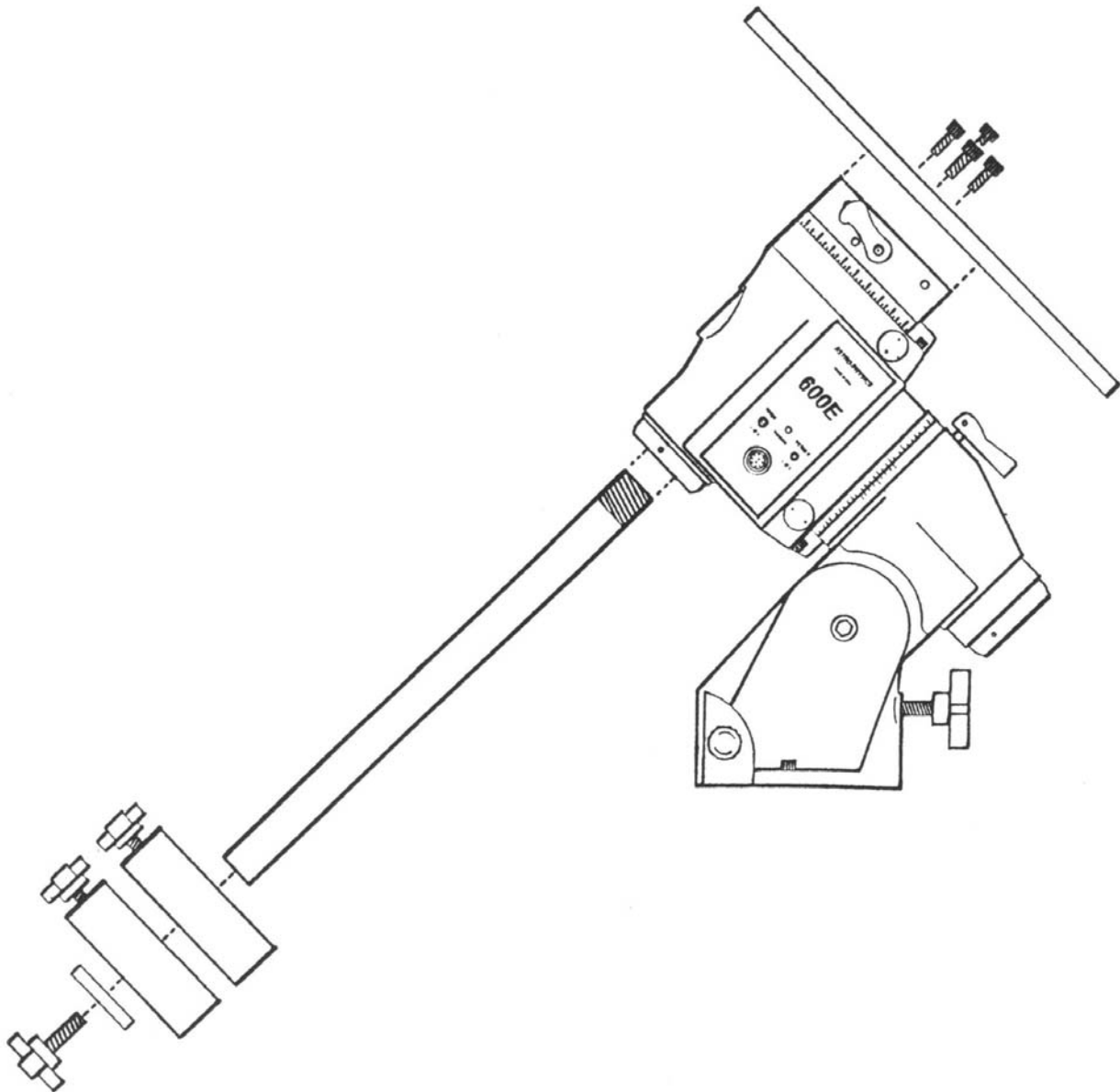

OPERATION OF THE MOUNTING

You can move your telescope to various objects either by grasping the telescope tube and moving it manually or by pressing the buttons on the controller.

Right Ascension Axis Clutch: The lever on the top of the polar axis is the clutch for that axis. The R.A. motor will not drive the R.A. clutch axis until this clutch lever is engaged.

Declination Axis Clutch: The lever just below the cradle plate is the clutch for the Dec. axis. The Dec. motor will not drive the Dec. axis unless this clutch lever is engaged.

Balancing Your Telescope: For proper operation, the telescope must be adequately counterbalanced. Start by balancing the tube assembly. Tighten the R.A. axis clutch lever, loosen the Dec. axis clutch clamp so that the telescope tube rotates on the declination axis. If you are using the dovetail plate, loosen the two side knobs and move the sliding bar, with scope attached, forwards and backward. If you are not using the dovetail plate, loosen the mounting rings and slide the tube up or down. The scope is balanced when it stays level with no clutch drag. Now, tighten the declination axis with the Dec. clutch lever and loosen the R.A. clutch lever. Move the counterweights up or down to achieve balance in R.A. Remember to allow for the extra weight of diagonals, eyepieces, and finder scopes. If the scope moves by itself, even when the clutches are loose, the scope is not fully counterbalanced precisely. A small amount of imbalance on the East side of the mount is permissible and even desirable for astrophotography and imaging.

FACE PLATE OF THE MOUNT HEAD AND CABLES

12VDC INPUT: Place the DC power cord into the phono plug outlet on the faceplate of the mount. Attach the opposite end to your power source. The control box and motors are designed to work at 12 volts DC. Suggested power sources include: portable rechargeable battery pack, auto battery, or power inverter for 110 volts. (1 Amp supply minimum.)

CONTROLLER INPUT: Place the connector of the controller cable into this receptacle. Do not overtighten the retaining ring.

RETICLE OUTPUT: If you wish to power your illuminated reticle from the same power source as your mount, place your reticle cord into the phono plug outlet on the faceplate. Use the MIN to MAX LED knob on the hand controller to adjust the brightness from minimum to maximum levels.

LED POWER INDICATOR: This LED will remain lit as long as the power from the battery is sufficient to operate the motor drive. If the LED begins to flicker, the battery power may be waning. You will notice a loss of function in the declination motor first if the battery is too weak.

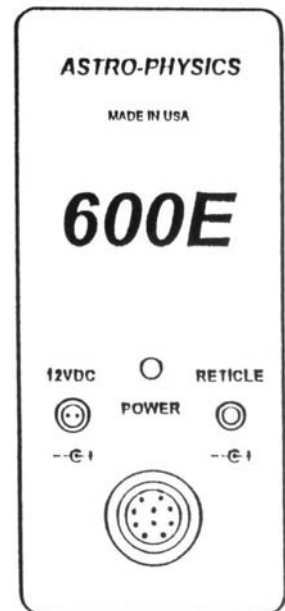

OPERATION OF THE CONTROLLER

The push button controller contains all the circuitry for driving the two motors. The controller will be operational when attached to both the faceplate of the mount and a power source. There is no on-off switch. The following diagram illustrates the controller and cables.

A very accurate quartz clock specifically calibrated for the drive gear is an integral part of the controller. The calibration is made to the King sidereal rate, which compensates for atmospheric refraction over a large part of the sky. With this tracking rate, it is easier to maintain critical guiding at high power. For the most sophisticated tracking of celestial objects, the controller has a built-in provision for attaching an ST-4 or ST-6 CCD imaging

camera/autoguider. Using the autoguider function, it is possible to take long exposure astrophotos totally unattended. You can walk away from the setup to enjoy other observing activities while your astrograph is in operation.

DRIVE ROTATION: If you are operating the 600E mount north of the equator, the HEMISPHERE switch must be set to "N". If south of the equator, set the switch to "S".

PUSH BUTTONS: The four red buttons are arranged so that the left and right buttons control the movement in right ascension, and the top and bottom buttons control the declination. This is the normal orientation of the objects in the eyepiece field. If the star moves down when you push the "N" button, move the DEC REVERSE switch into the opposite position. Pushing the right hand button "E" will cause the star to move to the right. If it moves to the left, move the RA REVERSE switch to the other position. When properly set up, the controller buttons will cause the object to move according to your orientation at the eyepiece.

MODE SWITCH: There are three guiding modes (rates): a 2x guiding rate, and a 8x and 16x slew rate. The slew rates are for positioning objects in the field, the guide rate is for fine guiding at high powers during astrophotography. Move the switch to select the mode that you prefer.

SELECT BUTTON: The control box has three drive rates to choose from: SID (sidereal), SOL (solar), and LUN (lunar). Select the position appropriate for the object under observation.

King Sidereal: Tracking rate for observing planets, stars, galaxies, and other distant objects.

Solar: Tracking rate for observing the sun.

Lunar: Tracking rate for observing the moon.

LED KNOB: There is an LED output available on the 600E face plate as shown in the diagram to the right. You may insert your LED reticle to this plug. Brightness can then be controlled using the MIN to MAX (minimum to maximum) setting of the LED knob.

AUTOGUIDER CONNECTION: If you own a Santa Barbara Instrument Group (SBIG) ST-4 or ST-6 Star Tracker/Imaging system, connect it to the controller via this 9 PIN connector. Call Astro-Physics to purchase a separate cable for this connection. The cable that we offer will allow your mount and ST-4 (ST-6) to operate from the same power source, if you choose.

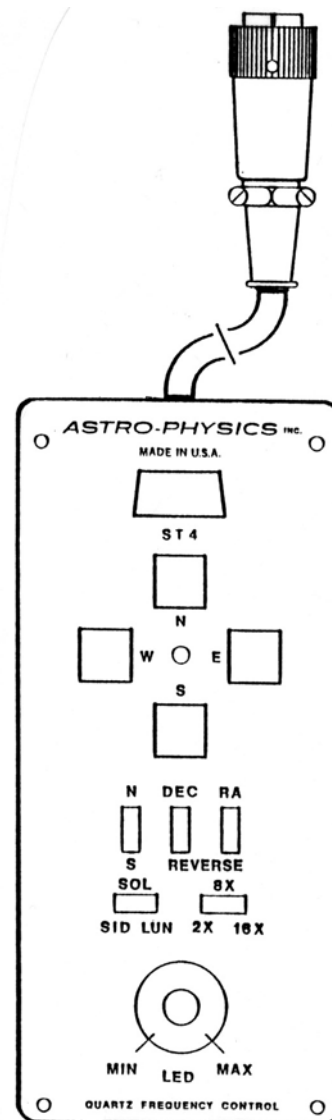

GUIDING YOUR ASTROPHOTOS

The natural tendency of astrophotographers is to push the directional button of the controller in the direction he or she wants the guide star to move until the star has centered itself in the guiding reticle. This method often results in overshooting the center of the reticle since the reaction time to let go of the button is often too late. By the time the gears in the drive motor have reversed and are driving again at the normal guiding rate, the star has moved past the center of the reticle. Then the opposite button is pushed to move the guide star back in the opposite direction toward the center and the same overshooting may occur.

The proper way to guide (and this will apply to almost any commercially available mounting) is to pulse your correction, much as the SBIG ST-4 does in its auto-guiding operation. Pulse the button for only a fraction of a second and note the new position of the guide star. If it has not moved far enough, pulse it again. Normally, it takes only one or two pulses to re-center the star in declination, since this drift will be extremely slow (assuming the mount was properly polar aligned). When the star needs to be reversed, it rarely takes more than 5 to 8 pulses in rapid succession, each lasting less than 1/10 second to get the star to re-center in the reticle. This same method should be used to keep the star centered in right ascension also. With some practice, you will be able to keep the guide star centered perfectly in declination with only an occasional pulse every 5 or 10 minutes while concentrating almost entirely on the right ascension drift.

MOUNT MAINTENANCE AND ALIGNMENT

Under normal operating conditions, no maintenance is required. Your 600E is a precision instrument with very accurate worm and wheel adjustments. Please be careful if you place the mount on a flat surface, i.e. the ground or trunk of your car. The gear alignment may be affected if the R.A. and Dec. motor/gear box assemblies sustain undue lateral force. This is true of any fine instrument. We suggest that you transport and store the mount in a case or in a well-padded box

NOTE: If your battery runs low, the declination motors will stop first, though the R.A. will continue to drive until the power is drained.

If any problems occur, please don't hesitate to contact Astro-Physics for assistance.

ASTRO-PHYSICS INC
11250 Forest Hills Road
Rockford, IL 61115
Telephone: (815) 282-1513
Fax: (815) 282-9847
www.astro-physics.com

Recommended reading:

The Backyard Astronomer's Guide, Terence Dickinson and Alan Dyer, Camden House Publishing, 1991. The authors, both former editors of *Astronomy* magazine, offer practical insight into astronomical equipment, finding your way around the sky, polar alignment, using setting circles, and astrophotography. This book provides excellent explanations and is well organized and illustrated.

All About Telescopes, Sam Brown, Edmund Scientific Company, 1975. This has excellent information regarding the principles of mount construction and operation, using setting circles, eyepiece projection, etc. Illustrations and formulas galore. Many of the instruments pictured are outdated, however the underlying principles are timeless.

INSTALLATION OF ENCODERS AND ENCODER HOUSINGS 600E MOUNT

Encoders for Digital Setting Circles: The declination axis of the 600EDA must be modified in order to use the encoders (part #ENC600). Later production runs already have this modification. Please call Astro-Physics for information on how you can tell if your mount is already modified and for further information about the (6ENMOD) modification if needed.

PARTS LIST

- 1 Right ascension (R.A.) Encoder housing (black anodize, with 3 thumbscrews)
- 1 Declination (Dec.) Encoder housing (black anodize)
- 1 R.A. Axis Adapter (clear anodized, silver), labeled R.A.
- 1 Dec. Axis Adapter (clear anodized, silver), labeled Dec.

To install your encoders, first remove your telescope from your mount. Remove your declination counter weight(s) *and* declination shaft.

FITTING DECLINATION ENCODER HOUSING

1. If the encoders were purchased with the 600E mount, it is likely that the declination axis adapter and encoder housing have already been installed. No further action will be required, as this encoder will remain in place.
2. If the encoders were purchased separately, the silver-colored Dec. axis adapter may be inside the black Dec. axis encoder housing. If it is, remove it now by grasping and pulling it out.
3. Thread the Dec. axis adapter into the end of your Dec. axis (from where you earlier removed the Dec. counterweight shaft). Final tightening should be done with firm hand pressure. Normally the Dec. axis adapter will not be removed.
4. If you look into the black encoder housing, you will see the encoder itself mounted at the rear of the housing. When this installation procedure is complete, the encoder shaft will insert into the center hole of the Dec. axis adapter. This allows the encoder to read the motion of the declination shaft as the declination axis moves.
5. Thread the Dec. encoder housing onto the Dec. axis housing of the 600E mount. You may need to wiggle the encoder housing gently to engage the shaft of the encoder with the hole in the center of the Dec. axis adapter. When the threading is complete, tighten up with firm hand pressure since normally this encoder housing will not be removed.
6. The counterweight shaft may now be rethreaded into the rear of the Dec. encoder housing.

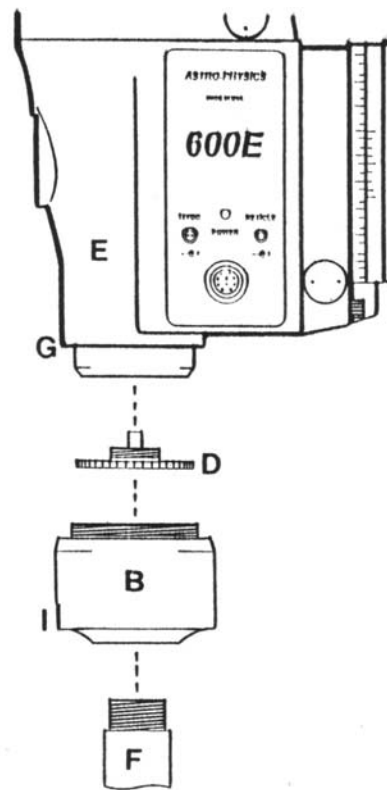

600E Mount Dec. Encoder Assembly

- B Declination (Dec.) encoder housing (encoder mounted inside)
- D Declination axis adapter
- E Declination axis housing of 600E mount
- F Declination counterweight shaft
- G Location to thread in encoder housing
- I Encoder lead socket (phone plug input)

FITTING RIGHT ASCENSION ENCODER HOUSING

1. Whether you purchased the encoders with the mount or as a later option, it is likely that you will need to install this encoder. The silver-colored R.A. axis adapter may be inside the R.A. axis encoder housing. If it is, remove it now by grasping and pulling it out.
2. Thread the R.A. axis adapter into the end of your R.A. axis. (If your polar alignment scope is already there, you must remove it first.) Use moderate hand pressure to tighten the R.A. adapter since you may need to remove it to install the polar axis telescope at a later time.
3. If you look into the black encoder housing, you will see the encoder itself mounted at the rear of the housing. When this installation procedure is complete, the encoder shaft will insert into the center hole of the R.A. axis adapter. This allows the encoder to read the motion of the R.A. shaft as the right ascension axis moves.
4. Now carefully slip the R.A. encoder housing onto the R.A. axis housing. You may need to wiggle the encoder housing gently to engage the shaft of the encoder (located within the R.A. axis housing) with the hole in the center of the R.A. axis adapter. Tighten the 3 thumbscrews evenly to secure in place.
5. Since the polar axis telescope and R.A. axis adapter thread into the same location, you will need to switch back and forth between them as needed. If you use the JMI "NGC MAX" or "Mini MAX" Digital Setting Circles, you can use the "polar align" mode in these units instead of a polar axis finder scope!

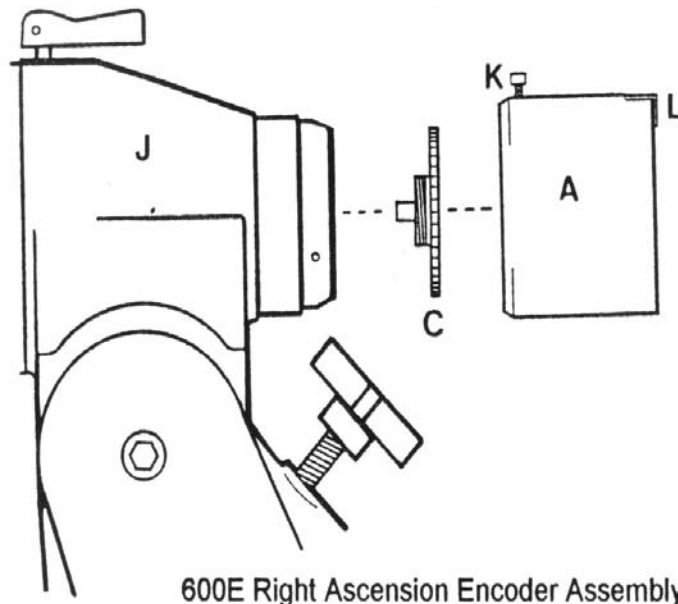

- | | |
|---|---|
| A | Right ascension (R.A.) encoder housing (encoder mounted inside) |
| C | Right ascension axis adapter |
| J | Right ascension axis housing |
| K | Thumbscrew |
| L | Encoder lead socket (phone plug input) |

The hardware for your encoders is now installed. For actual set-up procedures for "Micro MAX", "Mini MAX" or "NGC MAX" digital readouts, refer to the relevant operating manual.

PERIODIC MAINTENANCE

If you remove the R.A. encoder frequently, you may wish to use the very tiniest amount of auto grease on the mating threads.